



# SUNSTRIP40 PARKING GARAGE LUMINAIRE

0-10V DIMMING | SMART LIGHTING COMPATIBLE | EXTERNAL DRIVER



PRODUCT NAME	SUNSTRIP40
INPUT	700mA
POWER FACTOR	>0.9
POWER CONSUMPTION	13W or 19.5W
DIMMING	0-10V dimming
MATERIAL	Anodized extruded aluminum, glass lens
WEIGHT	0.3 lb (.15kg) or 0.6 lb (0.29 kg)
LENGTH	12" or 24"
MOUNTING	Surface Mount, Swivel Mount, Channel Mount, Mounted to Conduit
LIFETIME	> 60,000 hrs
WARRANTY	Ten year limited warranty
OPTICS	Milled aluminum primary optic, clear glass lens aluminum reflector, optional translucent diffuser
OPERATING RANGE	-30°C to 40°C
BEAM ANGLE	Recessed 90°, Standard 120°

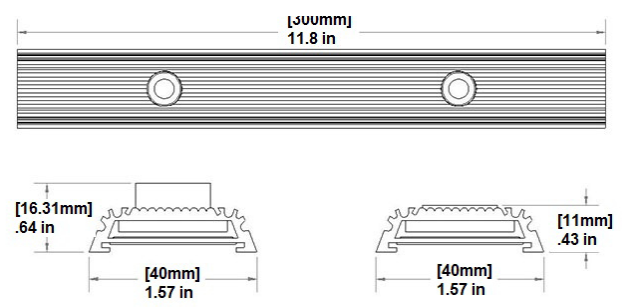

  DAMP/WET LOCATION [IP64/IP66]

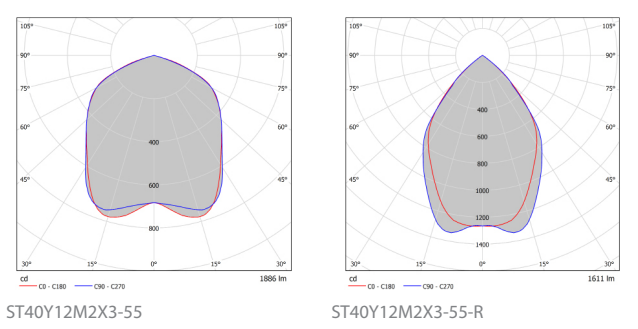

PRODUCT & LED MODULE SIZE	INPUT CURRENT	POWER CONSUMED	LUMEN OUTPUT	FIXTURE EFFICACY
ST40 M2X3	700 mA	13W	1886 LM	145 LM/W
ST40 M3X3	700 mA	19.5W	2829 LM	145 LM/W
Specialty designs with different chips per module available upon request				
CCT	2,700K	3,500K	4,100K	5,500K
LIGHT OUTPUT CONVERSION	.86	.90	.95	1
CRI	80	80	80	75

PRODUCT	LENGTH	LED MODULE SIZE	LED MODULE STYLE	CURRENT
ST40			-	-
ST40	Y12 12 INCHES	M2X3 2 MODULES 3 CHIPS EACH	N 120°	0700 700 mA
ST40	Y24 24 INCHES	M3X3 3 MODULES 3 CHIPS EACH	R 90°	

HOUSING COLOR	COLOR TEMPERATURE	MOUNTING BRACKET STYLE
-	-	
SV SILVER	55 5500K	SWV SWIVAL MOUNT
BK BLACK	41 4100K	CHM ADJUSTABLE CHANNEL MOUNT
CC CUSTOM COLOR	35 3500K	BFM BUTTERFLY MOUNT
	27 2700K	

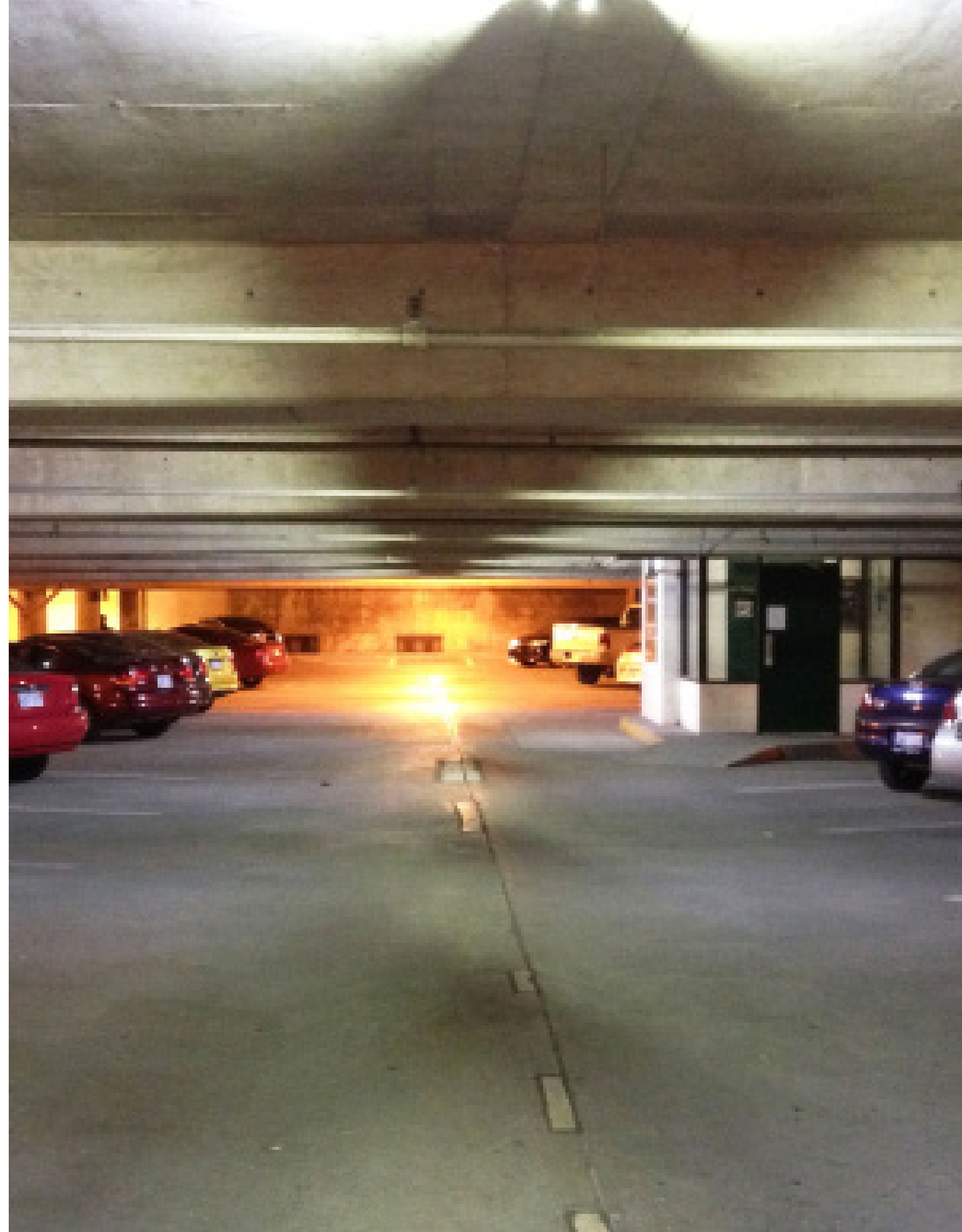

N-1